



**GRANI ROC**

Crta. León- Villaroaño, km 6,5  
24199 Marialba de la Ribera  
León - España

Tlf. (+34) 987 84 96 90  
Mvl. (+34) 619 212 534  
Fax (+34) 987 28 10 70  
info@grupohedisa.com  
www.grupohedisa.com

**PRODUCTO**



SPBO en un taller en España.

**DIAMOND WIRE SAW CUTTING MACHINE**

Type: Factory / Stationary  
Model: SPBO 2000 / 2500  
Purpose: Profiling  
2 Axes CNC

**The SPBO profiling machine of GRANI ROC is designed for a high precision dressing of blocks and slabbing and profiling production from stone blocks.**

**The machine is composed of a static structure and a mobile trolley. All the movements are controlled by a 2 axes CNC panel board.**

- The movements of the machine are controlled by a 2 axes CNC. The data can be input directly in the CNC or by an ISO code file generated by the CAD-CAM software GraniCAD supplied with the machine. This software allows to design the pieces to be profiled, to transfer the \*.dxf files to the CNC, to define the parameters of cutting in each step of the cut (speed of cutting, speed of the wire, etc.) and to simulate the path of the wire during the cut.
- Once the profiling file has been input in the machine board, the operator will have the possibility of modifying parameters such as cutting speed, wire speed with a full system of security on possible water shortage, wire broken, wire short or any kind of failure the machine may have
- The machine has an electric system for bringing closer the small guide wheels that allows the operator to adjust the cutting width until the one desired, reducing the arch value when cutting with diamond wire and thereby increasing its speed.
- The structure of the pillars and beam is made of electrowelded and machined tubes. The trolley is composed of electrowelded tubes forming a framework protecting all sensitive parts of the trolley like rod screws, wheels, etc.
- The tensioning of the wire is made pneumatic and automatically with indication of wire breakage or shortage. In this way the machine controls automatically the down movement of the machine, adapting it to the optimum working tension of the wire, avoiding possible breakages and optimizing its behaviour.
- All the main pulleys –drive and tensioning– and guiding wheels are protected by rubber liners in order to get the necessary traction of the wire. Such liners can be easily changed once they are worn out.
- The machine is equipped with an automatic cooling system for the diamond wire with detection of constant water pressure. This system stops the machine in the case of lack or insufficient water flow, protecting the tool and preventing possible deterioration or damage of the equipment.
- All the up and down screws are protected with hoods against dust and water
- The machines has an automatic greasing system that injects lubricating liquid in the critical parts of the machine ensuring their correct functioning and the long life of the spare parts.

**DESCRIPTION OF THE MACHINE**



**GRANI ROC**

Crta. León- Villaroaño, km 6,5  
24199 Marialba de la Ribera  
León - España

Tlf. (+34) 987 84 96 90  
Mvl. (+34) 619 212 534  
Fax (+34) 987 28 10 70  
info@grupohedisa.com  
www.grupohedisa.com

Front and side views of the SPBO profiling machine from Grani Roc.

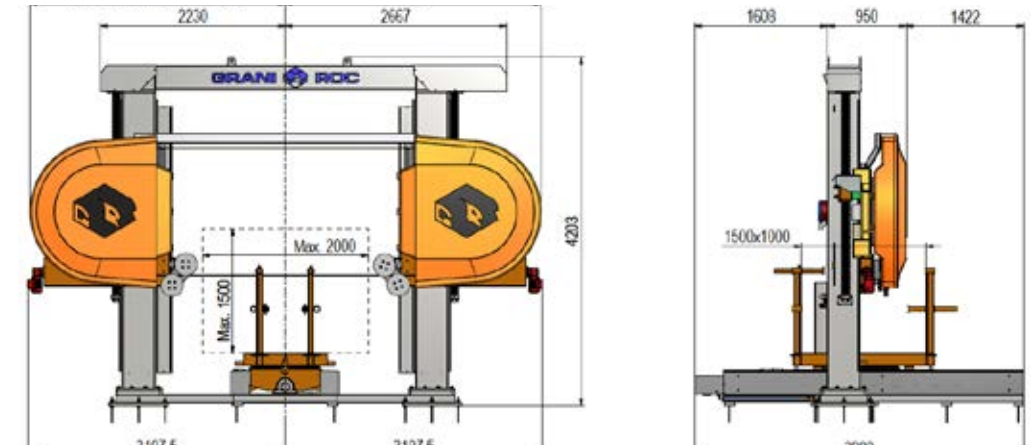

**TECHNICAL DATA**

	SPBO 2000	SPBO 2500
Maximum useful cutting width	2.000 mm	2.500 mm
Minimum useful cutting width	1.000 mm	1.300 mm
Maximum height of the block	1.500 mm	1.500 mm
Maximum length of the block	1.900 mm	2.500 mm
Downfeed speed of the wire	0 – 675 mm / min	
Forward speed of the trolley	0 – 9.000 mm / min	
Linear speed of the wire	0 – 40 m / s	
Length of the wire (approx.)	14,00 m	15,00 m
Diameter of the main wheels	1.500 mm	
Diameter of the guiding wheels	250 mm	
Dimensions of the trolley	1.000 x 1.500 mm	1.500 x 2.250 mm
Maximum weight on the trolley	10 T	
Total width of the machine (approx.)	6.400 mm	7.000 mm
Total height of the machine (approx.)	4.300 mm	
Total length (approx.)	4.000 mm	5.300 mm
Total weight (approx.)	6.400 kg	7.200 kg
Power of the main motor	7.5 kW	
Total installed power	12 kW	
Electrical connection	3 x 380 V + T + N	
Water flow	20 l / min a 4 bar	